

South Dakota



Answer Key

Career Awareness Activities Integrating Basic Academics

Kindergarten - Second Grade

**Take a peek
at what you
can become
right here in South Dakota!**

Labor Market Information Center
South Dakota Department of Labor and Regulation
1.800.592.1881
dlr.sd.gov/lmic

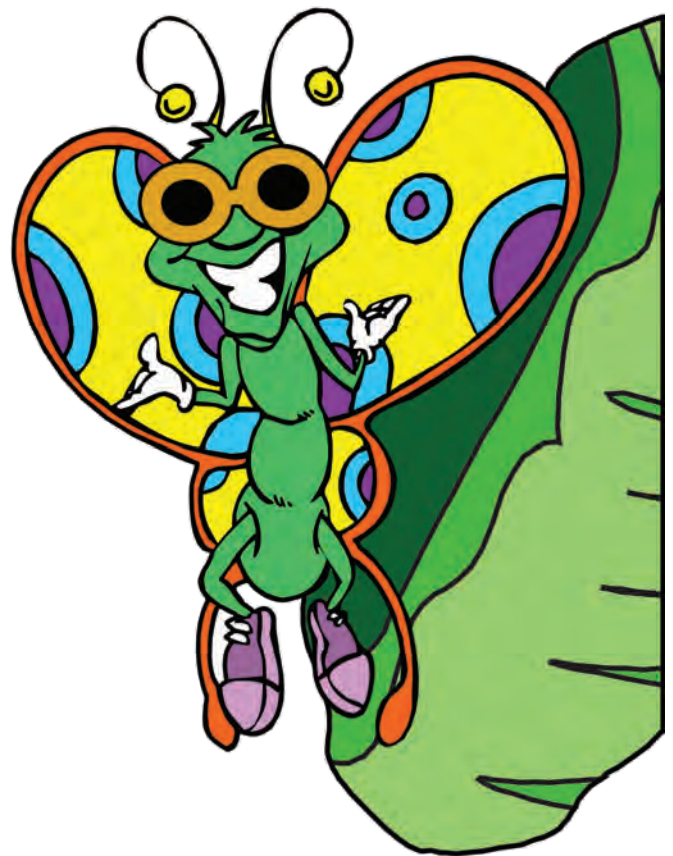

Please duplicate as needed for student use.

Answer key & activities available as PDF files at dlr.sd.gov/lmic

Auxiliary aids and services available upon request to individuals with disabilities. State and federal laws require the Department of Labor and Regulation to provide services to all qualified persons without regard to race, color, creed, religion, age, sex, ancestry, national origin, or disability. See dlr.sd.gov/lmic/eta_grant.aspx for details.

USDOL Funded

Rev. 05/19

South Dakota Career Peeks

Business Management &
Administration;
Finance

Accountants keep track of how much money people or companies earn and spend. They work in all kinds of places. They plan budgets. Budgets tell companies how much money they can spend.



Count the coins in the piggy bank. How much money is in the piggy bank?



98 ¢

Bonus: Pet's Playground got a bill. The bill is 74 cents. Does the piggy bank have enough money in it to pay the bill?

Yes. 74 cents is less than 98 cents.

Take a  **peek**

at what you can become!



South Dakota Career Peek

Architecture
& Construction

Architects create plans for places like homes, buildings, bridges and parks. They create places that are useful and safe. They also want them to look nice. They choose the building supplies. They draw detailed plans called blueprints.



Draw a house that is **longer** than this one.



Circle the apartment building that is **longer**.



Use a blue crayon to circle the bridge that is **shorter**.
Use a red crayon to circle the bridge that is **longer**.

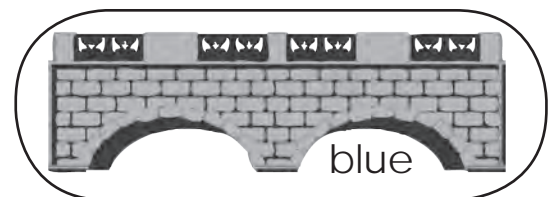
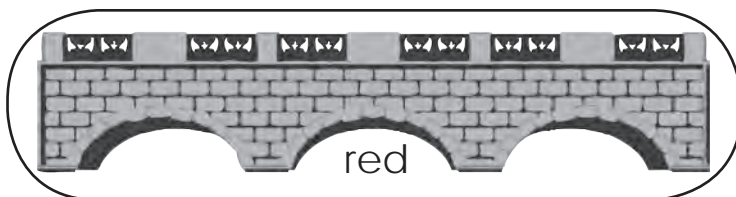

Take a  peek

at what you can become!



South Dakota Career Peeks

Manufacturing

Assemblers put things together. They work in factories. Some of them work on only part of a product. Some of them work on a whole product. They use many tools. They put together things like toys and cars. They work in teams.



Circle the bike that is on the left.

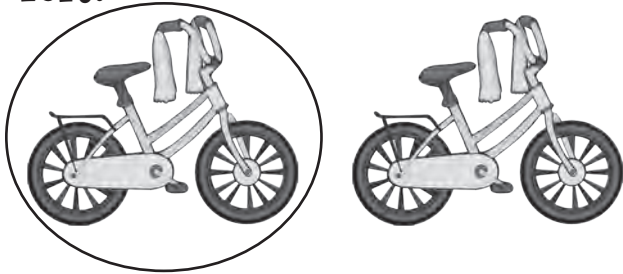

Circle the pacifier that is on the right.

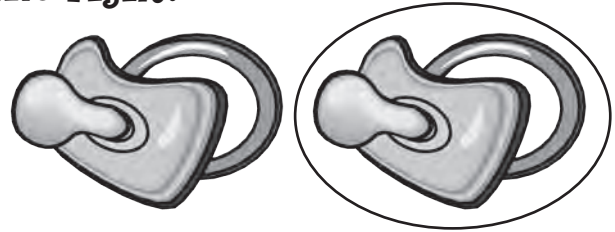

Color the lamp on the right blue.

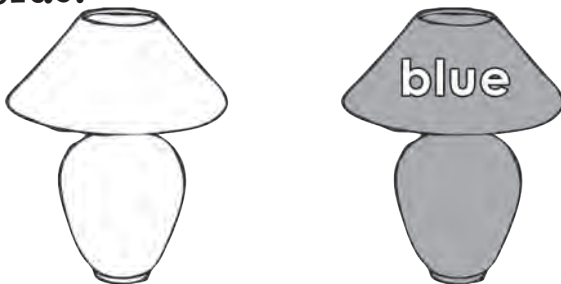

Draw a picture on the computer screen on the left.



Draw a beach ball on the right side of the umbrella. Draw a sun on the left side of the umbrella.



Take a  **peek**

at what you can become!





















South Dakota Career Peeks

Hospitality & Tourism
Cluster

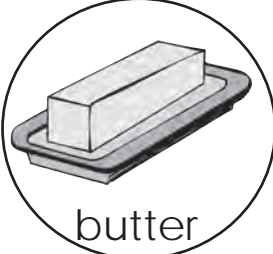

Bakers mix and bake food. They make things like breads, cakes and cookies. They follow recipes. They use mixers, measuring cups and spoons.

The pictures are things a baker might use or make. Loop the pictures that have the **vowel sound** of the letter shown.

	 pan	 bowl	 spoon	 can
	 mixer	 mitt	 pitcher	 spoons
	 cup	 board	 butter	 apron
	 pretzel	 blender	 cake	 bread

Take a  peek

at what you can become!



South Dakota Career Peeks

Architecture
& Construction

Carpenters build things. They work with wood. They use hammers, drills, saws and other tools. They make things like tables, houses and offices.



Count the things in each group. Put your answer on the line below each group. **Add** the groups together.



 2

+

 1

=

 3

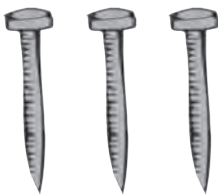

 3

+

 2

=

 5

Which tool would a carpenter **not** use? Circle it.



Take a  **peek**

at what you can become!



South Dakota Career Peeks

Architecture
& Construction



Cement Masons use concrete to build walls, sidewalks and fences. They smooth out the concrete once it is poured.

Some add color to concrete. They may use tools to make a pattern on the surface. Cement masons must know how the weather affects the hardening of the concrete to avoid cracks.

Suppose you are a cement mason hired to make a sidewalk for a hopscotch game. Fill in the missing numbers to find how many blocks are needed to complete the sidewalk.

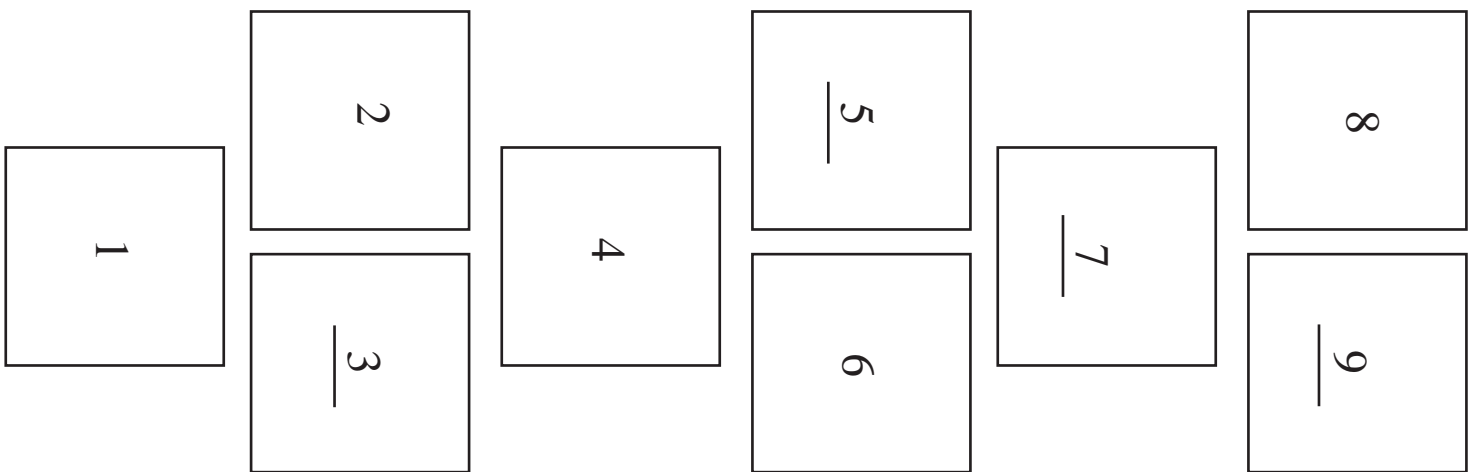

Nine blocks are needed to complete the sidewalk.

Take a  peek

at what you can become!



South Dakota Career Peeks

Education & Training;
Human Services

Child Care Workers take care of children while parents work. They feed children healthy foods. They keep them safe. They plan arts and crafts projects and games. They read to children. They teach them numbers and colors.

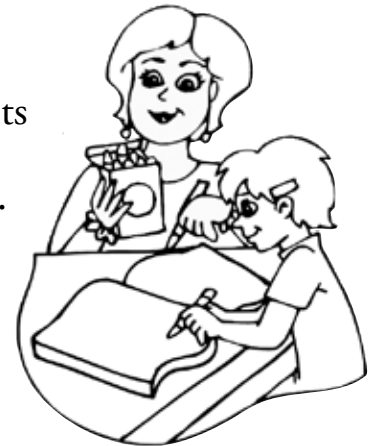

Match two pictures of things that rhyme with each toy (see next page).

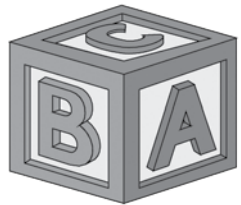

block

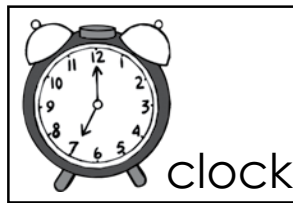

clock



sock

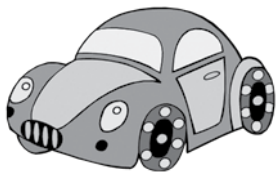

car



jar



star

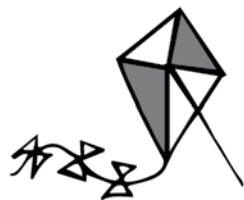

kite



night

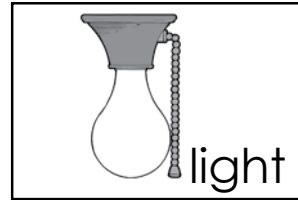

light



keys

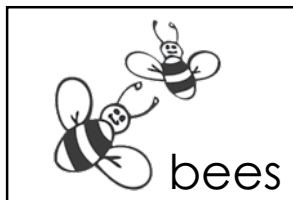

bees



peas

Take a **peek**

at what you can become!



South Dakota Career Peek

Education & Training;
Human Services

Child Care Workers, continued

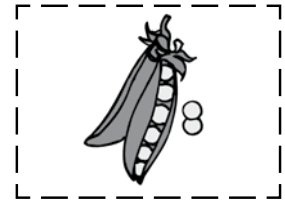
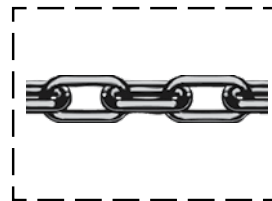
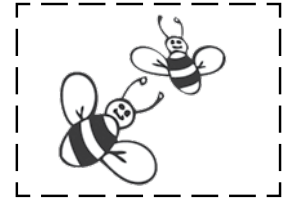
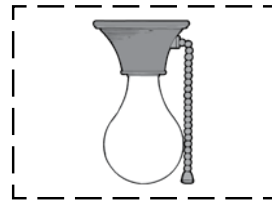
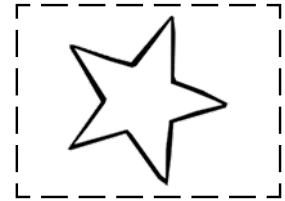
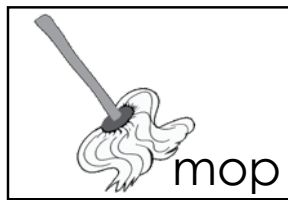
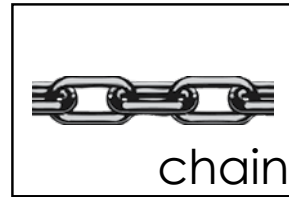
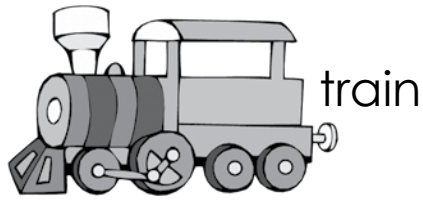

Bonus: Draw something that **rhymes** with red.

Take a  peek

at what you can become!



Career Peek

Clergy are leaders of some religious groups. Some are called ministers, pastors, rabbis or priests. They write and give talks. The talks are called sermons. They visit sick people. They lead weddings, baptisms and funerals.



Count the number of objects in each set. Write the number on the line.

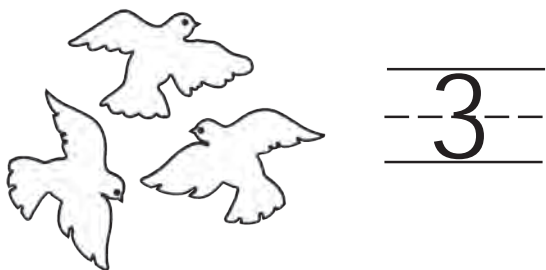
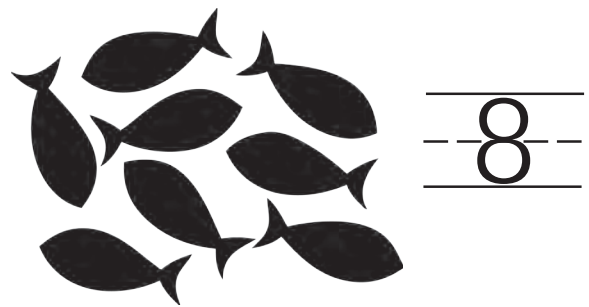
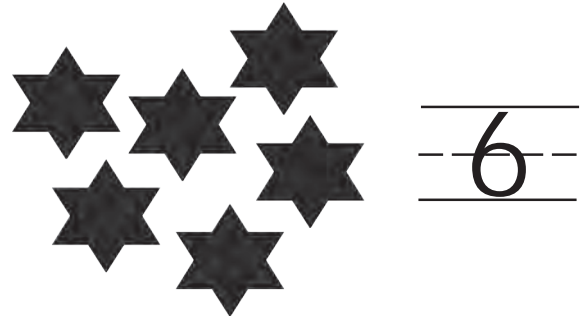
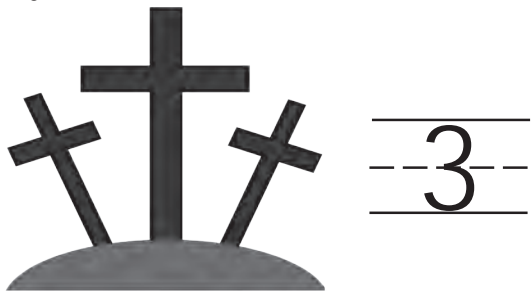

Take a  **peek**

at what you can become!











South Dakota Career Peeks

Education &
Training Cluster



Coaches in South Dakota teach student athletes. They help them learn to play a sport. Coaches who are also teachers are instead called teachers. These coaches teach the rules of the sport. They also help athletes improve their skills and techniques to help them win. Coaches may specialize in a variety of sports including basketball, football, gymnastics, track, soccer, swimming, tennis and wrestling.

Look at the chart below for a gymnastics competition. Draw the hands on the clock face to match the start and end times for each round. Write the total amount of time each round took on the line after the clocks.

Round	Event	Start Time	End Time	Start	End	Total Time
1	floor exercise	8:15	8:50			35 minutes
2	uneven bars	9:00	9:35			35 minutes
3	vault	9:45	11:05			1 hour & 20 minutes
4	balance beam	11:20	12:10			50 minutes



at what you can become!



South Dakota Career Peeks

Architecture &
Construction Cluster



Construction Supervisors oversee workers who build things. The workers may build houses or other buildings. They may pour concrete. They may install electricity. Some put plumbing in buildings. Others lay flooring. The supervisors make sure work is done correctly and on schedule.

Match the picture, by drawing a line, with the correct word for things a construction supervisor may oversee being built.

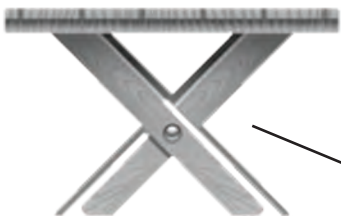

hospital

road

table

bridge

Take a  peek

at what you can become!



Career Peeks

Dental Hygienists help take care of people's teeth and gums. They clean teeth. They check to see if a patient's mouth is healthy. They take X-rays of teeth. They teach patients how to take care of their teeth and gums.



Cross out the things that do not help keep teeth healthy. What letter do the things you did not cross out start with? Write that letter on the line to the left.

Example:

t



toothbrush



toothpaste



m

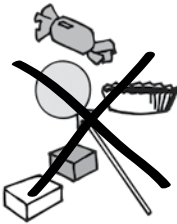

milk



meat

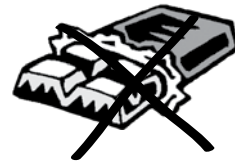

f



fruit



floss

c



corn

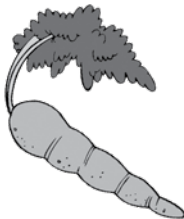

carrot

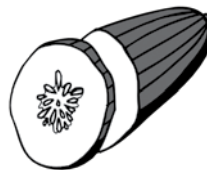

cucumber



Take a **peek**



at what you can become!



South Dakota Career Peek

Architecture
& Construction
Cluster



Drafters draw plans. Workers use the plans to build things.

The plans show workers how to make things like houses, cars, buildings, machines and toys. Most drafters use computers.

Below are objects a drafter might draw. **Count** the number of shapes in the objects. Write the number in the blank space.

How many **rectangles** can you find?



8

How many **triangles** can you find?

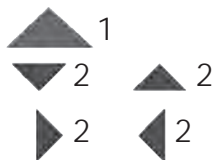

9

How many **circles** can you find?

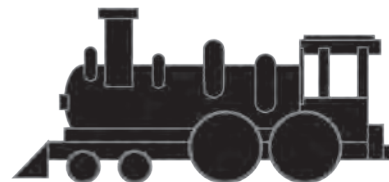

4

Bonus: Draw a picture of something a drafter would draw. Use lots of shapes in your drawing. Draw it on the back of this paper.



at what you can become!



South Dakota Career Peek

Architecture &
Construction Cluster

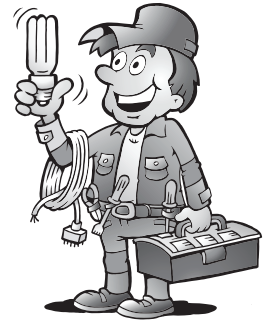

Electricians install and fix wiring. They give power to homes and businesses. They use hand tools and power tools. They also read maps to find outlets.

Circle the items that use electricity.

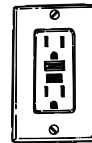

(Hint: They must plug into an outlet in the wall).

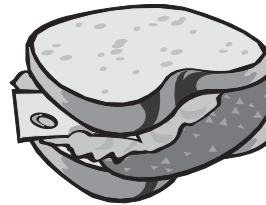
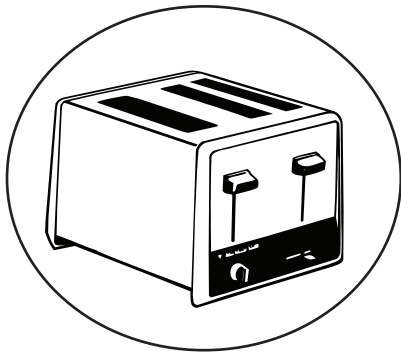

Draw two more items that use electricity:

1.

2.

Take a  peek

at what you can become!



South Dakota Career Peeks

Architecture
& Construction;
Science, Technology,
Engineering &
Mathematics

Engineers come up with ways to fix problems. They want to know how things work. They ask why things work. They draw plans. They make things like machines, roads, buildings, toys, light bulbs, software, medicines, robots or tools. They use science and math.



Connect the dots to see what the engineer is designing.

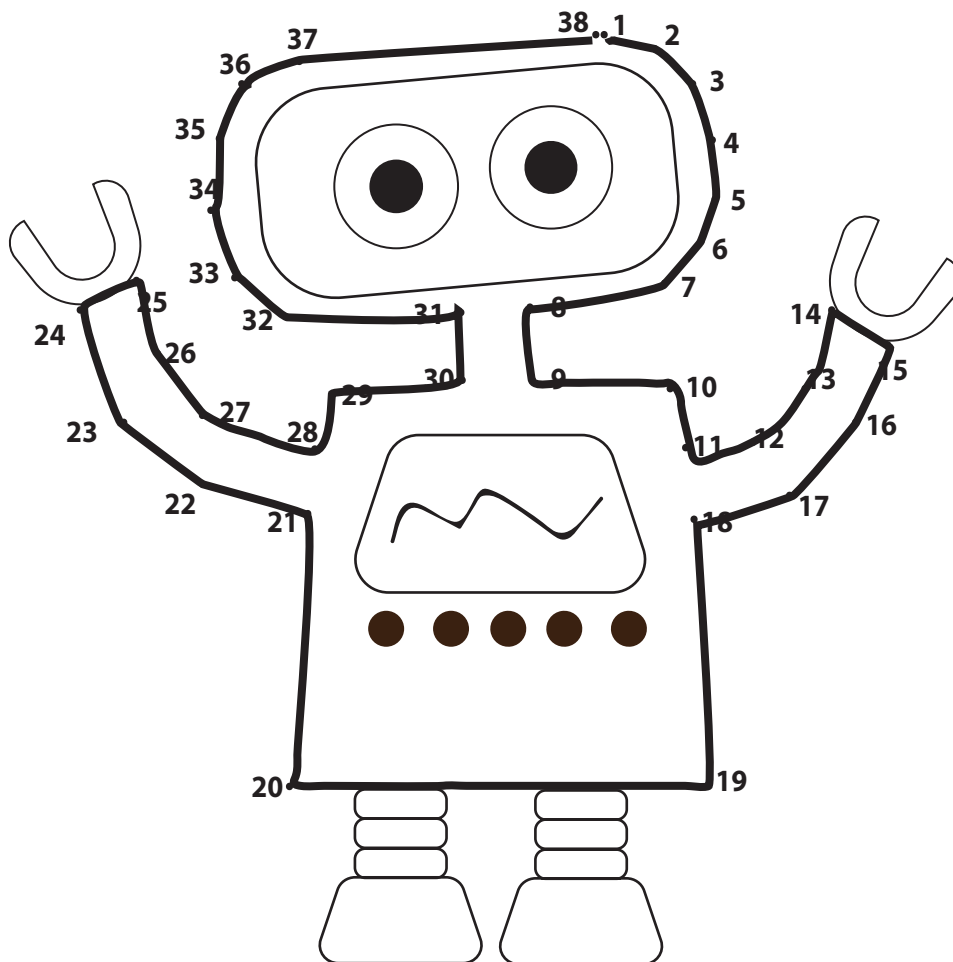

Take a  peek

at what you can become!



South Dakota Career Peeks

Law, Public Safety,
Corrections &
Security

Firefighters put out fires. They try to save people and property. They want to prevent fires. Some make sure fire safety laws are obeyed. They teach people about fire safety. They help people who are hurt or sick.



Circle the fire truck that is the longest.

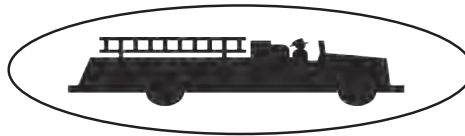

Circle the fire hydrant that is the tallest.



Circle the fire that is the widest.



Take a  peek

at what you can become!



South Dakota Career Peek

Hospitality & Tourism
Cluster



Food Service Supervisors oversee workers who make and serve food. The workers may cook food. They may make cold foods like ice cream cones or salads. Other workers, like waiters and waitresses, take orders and serve food. The supervisors make sure food is made and served correctly.

Think about all the colors and shapes of food and fill in the blanks below.

1. Name a food that is red. tomato, apple, cherry, watermelon, etc.
2. Name a food that is round. pizza, pie, bologna, orange, cookie, etc.
3. Name a food that is green. lettuce, beans, kiwi, broccoli, etc.

Pretend you are a food service supervisor and need to pick two favorite foods to serve in the restaurant where you work. What foods would you serve?

1. _____
2. _____

Bonus Activity: Use a blank sheet of paper to design a menu for the restaurant, showing the three food options above. (Tip: pictures make menus more interesting!)



at what you can become!



South Dakota Career Peeks

Business Management &
Administration Cluster

General Managers are responsible for the overall operations of a company or agency. They make rules, oversee daily operations, and plan the use of materials and workers.



Suppose you are the manager of an ice cream shop. Circle the things below you would need to operate the shop.



Ice cream

Pepperoni

Pizza sauce

Ice cream scoopers

Ice cream toppings

Plastic dishes

Workers

Spoons

Ice cream cones

Pizza crust

Freezer

Oven

Bonus: Suppose the ice cream shop makes a profit of 50 cents on each ice cream cone sold (after subtracting all the costs involved in making each cone). If the shop sells 35 cones in one day, what is the total profit?

Take a  peek

at what you can become!



South Dakota Career Peeks

Human Services
Cluster

Hair Stylists wash, cut and style hair. They color hair.

Some style hair for weddings and proms. Some take care of customers' skin, fingernails and toenails.



The words and pictures are things hair stylists use. **Match** the word to the correct picture.

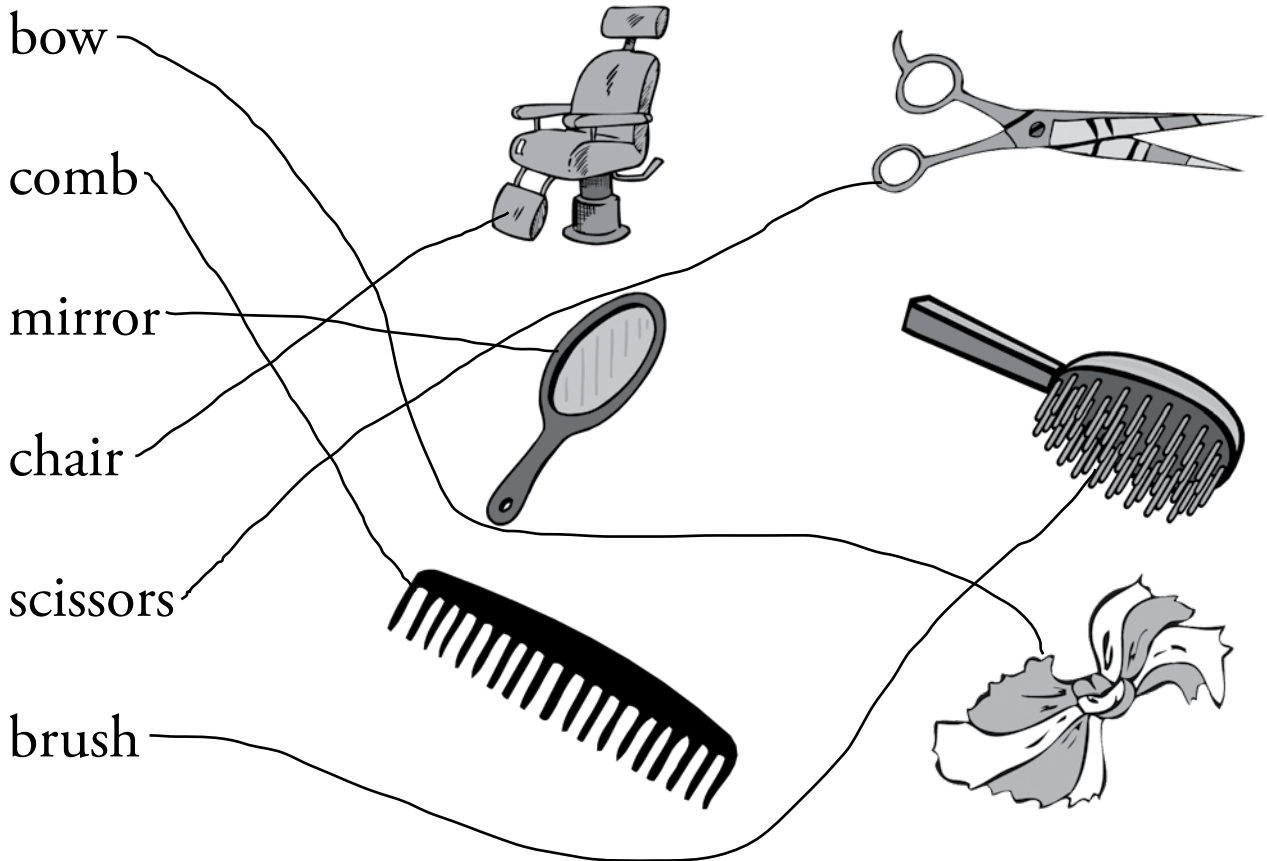

Take a  **peek**

at what you can become!



South Dakota Career Peeks

Transportation,
Distribution & Logistics



Highway Maintenance Workers keep streets and highways in good condition and safe to drive on. They patch broken pavement. They may repair guard rails on the side of the road or fix highway signs. Highway maintenance workers may also install or fix fence near roadways to catch snow in the winter.

Circle the types of vehicles that use highways. They are just a few of the reasons it is important our roads be safe!

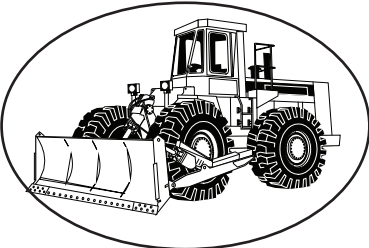
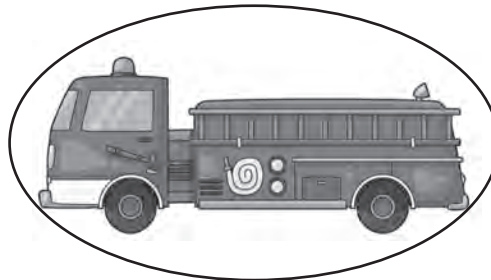

Take a  **peek**

at what you can become!



South Dakota Career Peeks

Transportation, Distribution
& Logistics Cluster

Industrial Tractor Operators run equipment like a fork lift to safely move materials around in a warehouse, storage yard, factory, construction site or similar place.



A fork lift driver is given the warehouse map below and told to move cartons to the locations listed. Color in the correct sections to show where the cartons should go.

Use red for cartons going to row 3, section 4.

Use blue for cartons going to row 1, section 5.

Use green for cartons going to row 2, section 2.

Use yellow for cartons going to row 3, section 1.

	Section 1	Section 1	
	Section 2	Section 2	
Row 1	Section 3	Section 3	Row 2
	Section 4	Section 4	
	Section 5	Section 5	
	Section 6	Section 6	

	Section 1	Section 1	
	Section 2	Section 2	
Row 3	Section 3	Section 3	Row 4
	Section 4	Section 4	
	Section 5	Section 5	
	Section 6	Section 6	

Take a  peek

at what you can become!



South Dakota Career Peek

Finance Cluster



Insurance Sales Agents sell different types of insurance. People buy insurance to protect what they have if bad things happen. For example, people insure their vehicles. If they have an accident, they can get it fixed or buy a different one. These agents explain to customers what types of loss would be covered by insurance. They also teach customers safety tips to help them avoid loss.

Safety precautions help prevent bad things from happening. Check off the things below you do to be safe.

- Wear my seat belt whenever I ride in a vehicle.
- I know how to dial 9-1-1 if there is an emergency.
- I know my full name, phone number and address if I have to ask a police officer or other adult for help.
- My house has smoke detectors.
- If there is a fire at my house, I know the safest way to get outside and where to go.
- Wear my helmet when I ride a bike, board or scooter.



at what you can become!



South Dakota Career Peeks

Law, Public Safety,
Corrections &
Security

Lawyers help people with laws. Some speak in courtrooms. Some write wills, leases or contracts. Some lawyers defend people or companies in court. If people break the law, some lawyers try to send them to jail. They study the law for many years.



Lawyers read and write a lot. Write the missing word in the sentences.



She walks to the park.

She Eggs Ready

Can we go to the lake?

jumps lake now

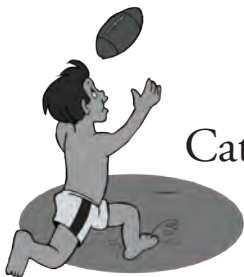

Catch that ball!

think ball nine

The book is about a panda.

sleepy panda won



Take a  peek

at what you can become!



South Dakota Career Peeks

Finance Cluster

Loan Interviewers work with people who want borrow money. They gather information from the people. They complete documents related to the loan. They may double check the information people provide to make sure it is correct.



Circle the pictures below of things a loan interviewer may use to gather information and complete documents.

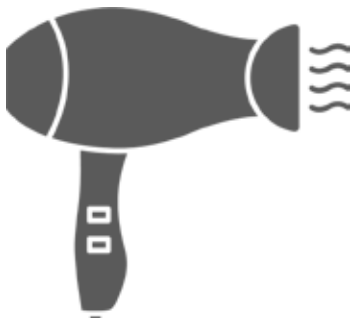

Take a  peek

at what you can become!



South Dakota Career Peek

Finance Cluster



Loan Officers meet with people applying for loans. They review applicants' financial records and figure out how much money they may be able to borrow. Loan officers work at banks, colleges and mortgage firms.

Figure out which applicant would be able to pay back a loan the soonest. Add the items in each group. Write your answer on the line next to each group. Circle the answer with the most money.

Applicant A

$$\begin{array}{ccccccc} \text{\$} & + & \text{\$} & + & \text{\$} & + & \text{\$} & = & \text{\textcircled{4}} \end{array}$$

Applicant B

$$\begin{array}{ccc} \text{\$} & + & \text{\$} & = & \underline{\quad 2 \quad} \end{array}$$

Take a



peek

at what you can become!



South Dakota Career Peek

Government & Public
Administration

Mail Carriers take care of letters and packages. They sort mail. They bring mail to homes and companies.

They work outdoors in all kinds of weather. They are given mail routes. In cities, most of them walk these routes. In areas that are more rural, they drive to places on their routes.

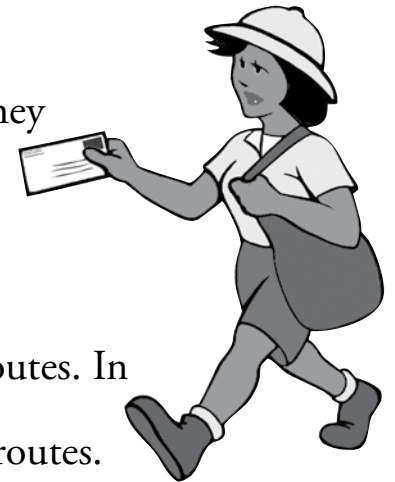

Mail carriers know their ABCs. **Connect the dots** from A to Z

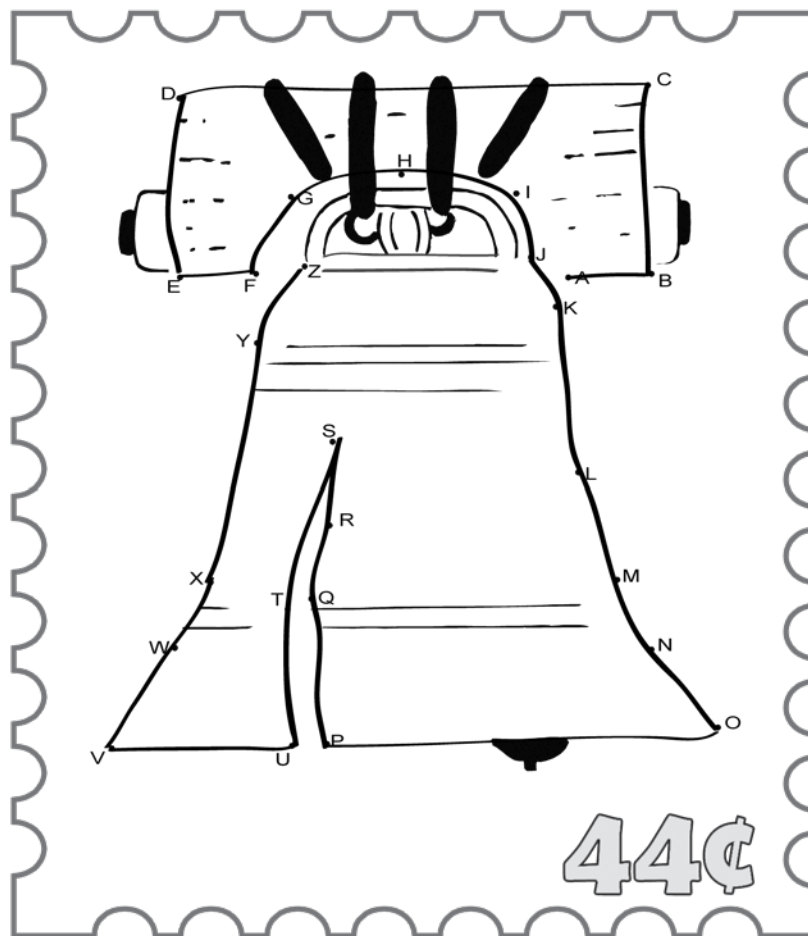

Take a  peek

at what you can become!



Career Peek

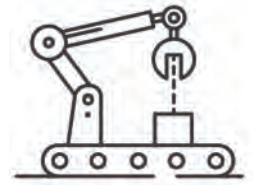

Maintenance and Repair Workers fix and maintain machines, equipment and buildings. They may paint or do repairs on windows or doors. They also do basic electrical, plumbing or welding work.

Each of the words below are tools a Maintenance and Repair Worker may use. Find out how much each word is worth using the letter tiles below.

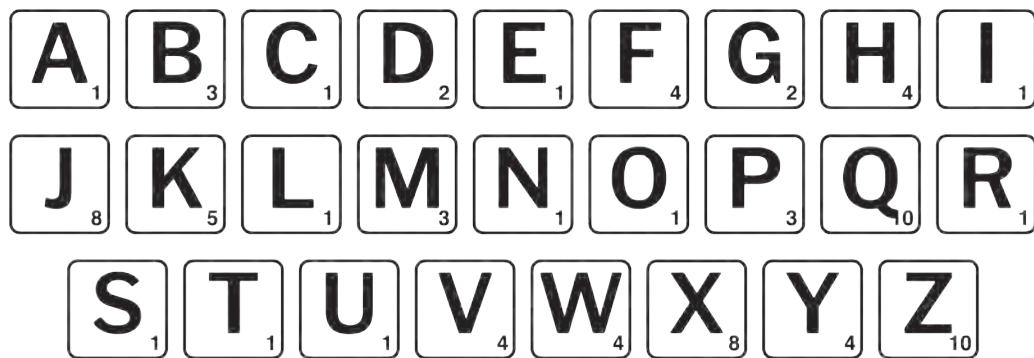
wrench = 12pliers = 8hammer = 13saw = 6paintbrush = 17flashlight = 20screwdriver = 18drill = 6

at what you can become!



South Dakota Career Peek

Business
Management
& Administration

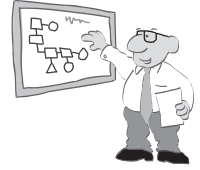

Management Analysts help organizations run more efficiently.

They give managers ideas on ways to cut down on costs and make more money. They study problems in companies and think of ways to fix the problems.

They may suggest doing tasks in a different order. Or they may think different tools or equipment will help the company run more smoothly.

Management analysts take all pieces of a project and fit them together to create a whole product. Cut out each of the jigsaw puzzle pieces, and fit them together to make a complete puzzle.

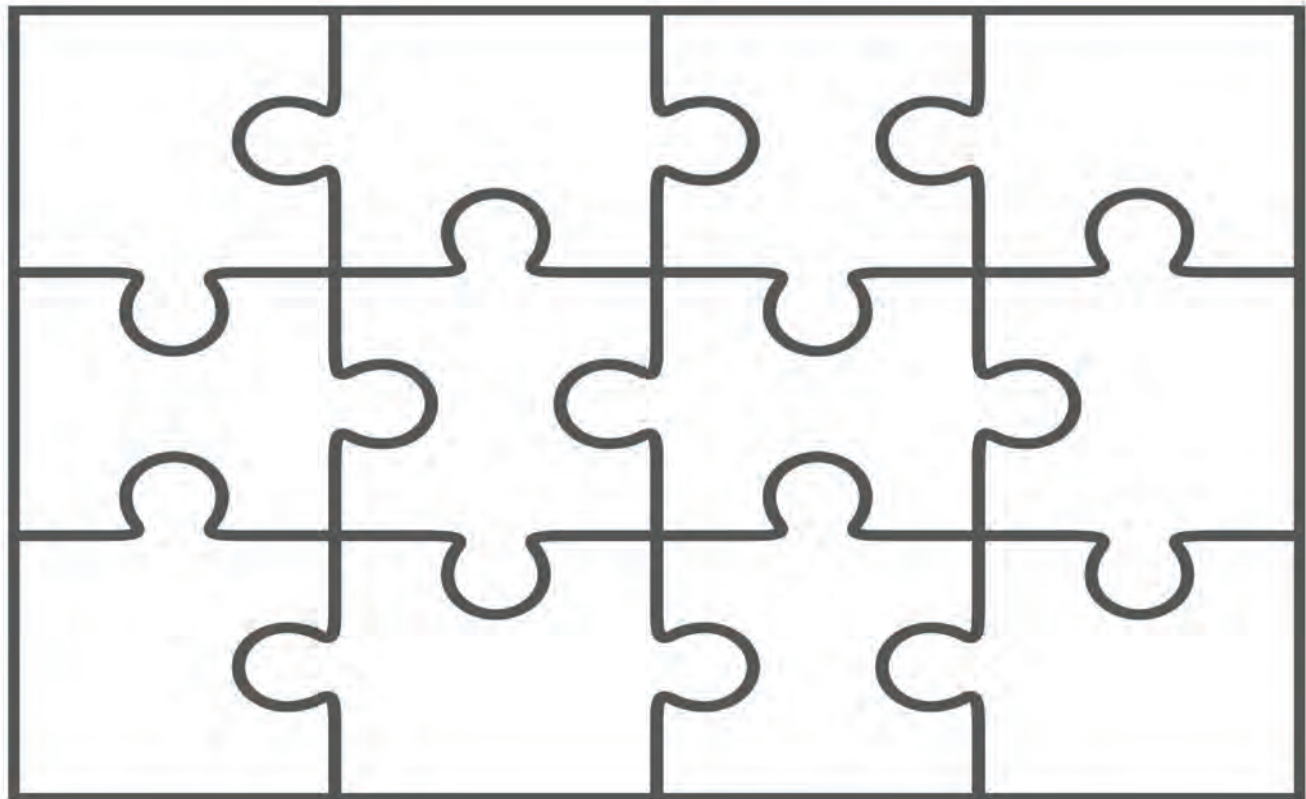

Take a  **peek**

at what you can become!



South Dakota Career Peeks

Business
Management
& Administration

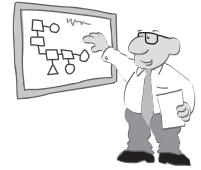

Management Analysts, continued

Pretend you are a management analyst trying to help a company that sells sack lunches. They need help packing the lunches more quickly. Below are the tasks involved in making the food and packing the lunch. Read through them all. Draw a line to the tasks 1 through 8 to show in what order you think they should be done.

- 1 After the sandwich is made, put it in a baggie.
- 2 Pack an apple into the lunch sack.
- 3 Pack the baggie of carrot sticks into the lunch sack.
- 4 Pack the baggie with the sandwich in it into the lunch sack.
- 5 Make a sandwich from the two pieces of buttered bread, adding two slices of ham and a slice of cheese.
- 6 Put several carrot sticks in a baggie.
- 7 Butter two slices of bread to make a sandwich.
- 8 Open the sack so it is ready to pack the food.



Take a  peek

at what you can become!



South Dakota Career Peek

Manufacturing;
Transportation,
Distribution & Logistics

Mechanics fix and maintain machines and motors. Some work on cars or motorcycles. Some work on big machines or equipment. They figure out why things do not work. They use many tools. Some use computers.



The pictures are things a mechanic would use. **Count** the number of things in each group. Write the number on the line.



5

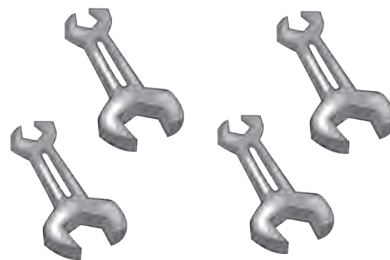

4

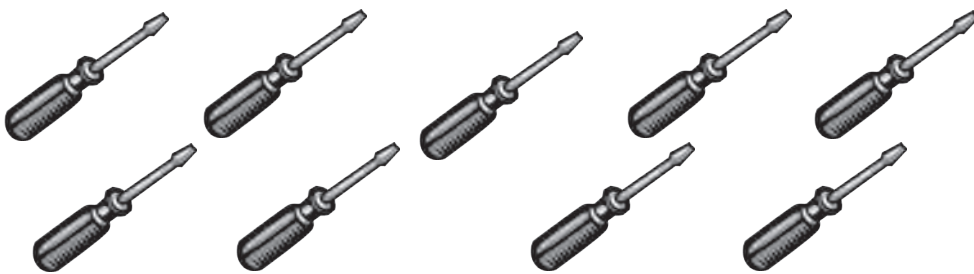

9



8

Take a  **peek**

at what you can become!



Career Peek

Nurses take care of sick and hurt people. They help doctors look at and treat patients. They help with medical tests and give patients medicine. They try to help people stay well. They work in hospitals, clinics, nursing homes, schools and patients' homes.

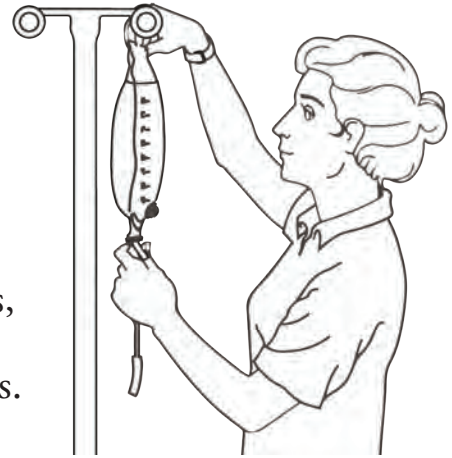

Count the number of dots on each bandage. Put number in the square on the bandage.



This bandage is missing dots!
There should be 24.
How many are missing?

$$24 - \boxed{21} = \underline{\quad 3 \quad}$$

Put number from square here too.



This bandage is missing dots!
There should be 18.
How many are missing?

$$18 - \boxed{9} = \underline{\quad 9 \quad}$$

Put number from square here too.



at what you can become!



South Dakota Career Peek

Business Management &
Administration Cluster



Office Supervisors oversee workers who do many types of work, usually in an office. The workers may type or file papers. They may keep records of money or prepare bills. They may answer phones. Many use computers in their work. The supervisors make sure workers know how to do their jobs. They correct their mistakes.

Office Supervisors often write or proofread reports. Pretend you are an Office Supervisor and have to review the report on the next page to make sure it is correct. Do the following:

1. Read the report.
2. Fill in the blanks with the most logical word from the box at the top.
3. Circle any misspelled words and other errors.
4. Check the math and correct any mistakes.

Take a  peek

at what you can become!



South Dakota Career Peeks

Business Management & Administration Cluster

Office Supervisors Activity, continued

germs	missing	supplies	folders
meeting	machine	pencil	hand

Inventory Report

The order clerks took inventory of the office _____ supplies _____ on April 3. This is a report of their findings.

Inventory of Paper	
Color of Paper	Number of Boxes
White	16
Blue	4
Yellow	2
Greene	1
Total	23

The table at the right (should be left) shows how many boxes we have of each color of paper.

They also counted the boxes we have of file _____ folders _____, staples, paper clips and pens. They suggest we order more of those supplies, as shwon in the table below.

They also recommend we buy bottles of _____ hand _____ sanitizer to give to all staff to prevent the spread of _____ germs _____.

There were too items they could not find. We believe they are _____ missing _____. One was the computer from the _____ meeting _____ room. The other missing item is the electrical _____ pencil _____ sharpener which belongs by the copy _____ machine _____. These items will need to be replaced.

Supplies to Order	
Item	Number of Boxes
File Folders	6
Staples	22
Paper Clips	8
Pens	3
Hand Sanitizer	34
Total	73

Bonus question: What two items should be added to the list at the right of supplies to order? electric pencil sharpener, computer for meeting room



at what you can become!



South Dakota Career Peeks

Architecture &
Construction Cluster



Operating Engineers drive or control heavy machines used to build roads, bridges, buildings and other structures. They dig and move dirt, build structures, and pour concrete and pavement. They also repair and maintain equipment.

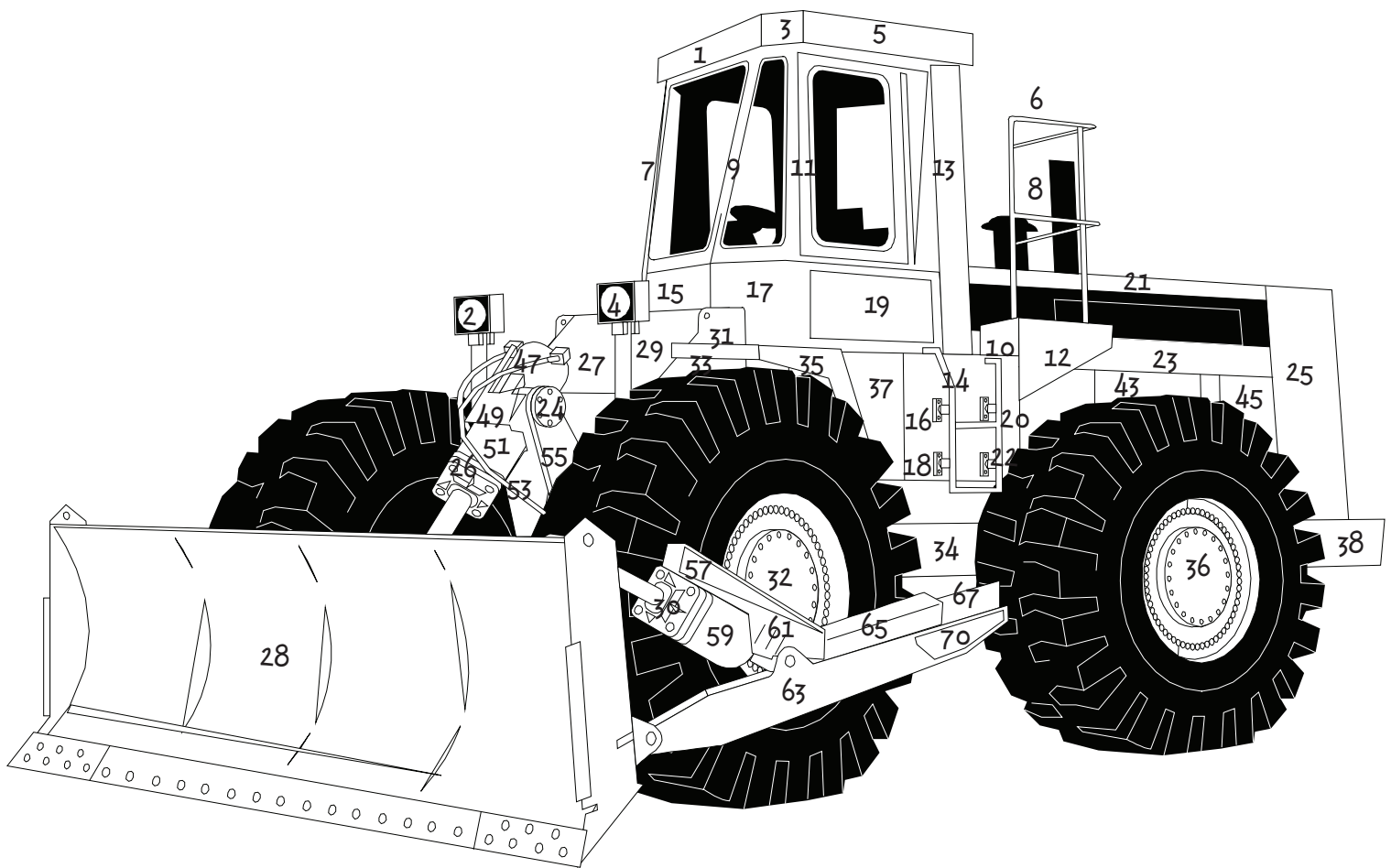

Take a  peek

at what you can become!



Career Peek



Parts Salespersons sell spare and replacement parts and equipment in repair shops or parts stores. They process sales and help customers find the right products for cars or tractors.

Figure out how much change each customer will get back at the car parts store.

Sally has:



1 battery costs:

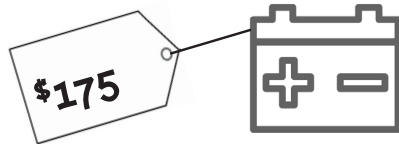

What will her change be?

\$25.00

Tom has:



1 tire costs:



What will his change be?

\$80.00

Jennifer has:



1 spark plug costs:

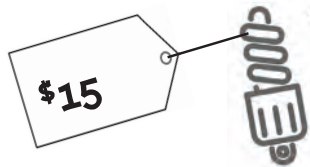

What will her change be?

\$85.00



at what you can become!



South Dakota Career Peeks

Arts, Audio/Video
Technology &
Communications

Photographers take pictures. They may work for websites, newspapers or magazines. Some work in studios. They take pictures of people, food and other things. Some take school pictures. Some take pictures at weddings.



Look at the pictures. Circle the **changes**.



Take a  peek

at what you can become!



South Dakota Career Peeks

Transportation,
Distribution & Logistics
Cluster

Pilots fly airplanes and helicopters. They move people, cargo and mail. Pilots look at maps. They check out weather reports. They plan the routes they take. They must keep records of their flights.



Add the math problems in the picture. Then color the picture. Use these colors for the sums of the math problems:

3
yellow

4
red

5
blue

3
 $\begin{array}{r} 3 \\ + 2 \\ \hline 5 \end{array}$
blue

2
 $\begin{array}{r} 2 \\ + 2 \\ \hline 4 \end{array}$
red

1
 $\begin{array}{r} 1 \\ + 4 \\ \hline 5 \end{array}$
blue

5
 $\begin{array}{r} 5 \\ + 0 \\ \hline 5 \end{array}$
blue

4
 $\begin{array}{r} 4 \\ + 1 \\ \hline 5 \end{array}$
blue

1
 $\begin{array}{r} 1 \\ + 2 \\ \hline 3 \end{array}$
yellow

0
 $\begin{array}{r} 0 \\ + 5 \\ \hline 5 \end{array}$
blue

2
 $\begin{array}{r} 2 \\ + 3 \\ \hline 5 \end{array}$
blue

4 + 0 = 4 red

1 + 3 = 4 red

2
 $\begin{array}{r} 2 \\ + 3 \\ \hline 5 \end{array}$
blue

4
 $\begin{array}{r} 4 \\ + 1 \\ \hline 5 \end{array}$
blue

3
 $\begin{array}{r} 3 \\ + 0 \\ \hline 3 \end{array}$
yellow

0
 $\begin{array}{r} 0 \\ + 5 \\ \hline 5 \end{array}$
blue

Take a  **peek**

at what you can become!



South Dakota Career Peeks

Architecture &
Construction

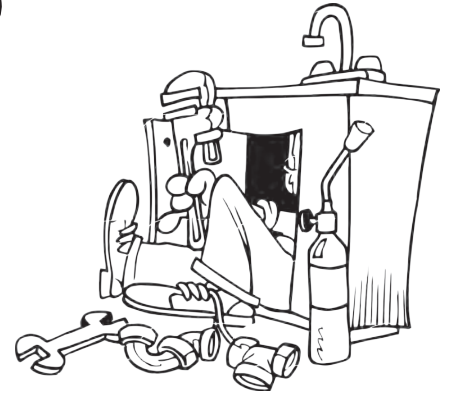

Plumbers install and repair pipes. Pipes carry water, steam, air or gases. Plumbers work in homes, businesses and factories. They use tools like drills, saws, torches and wrenches.

They install sinks or showers in homes and places of work.

What's in the plumber's toolbox? Draw a line from the item to the toolbox for all the tools a plumber would use.

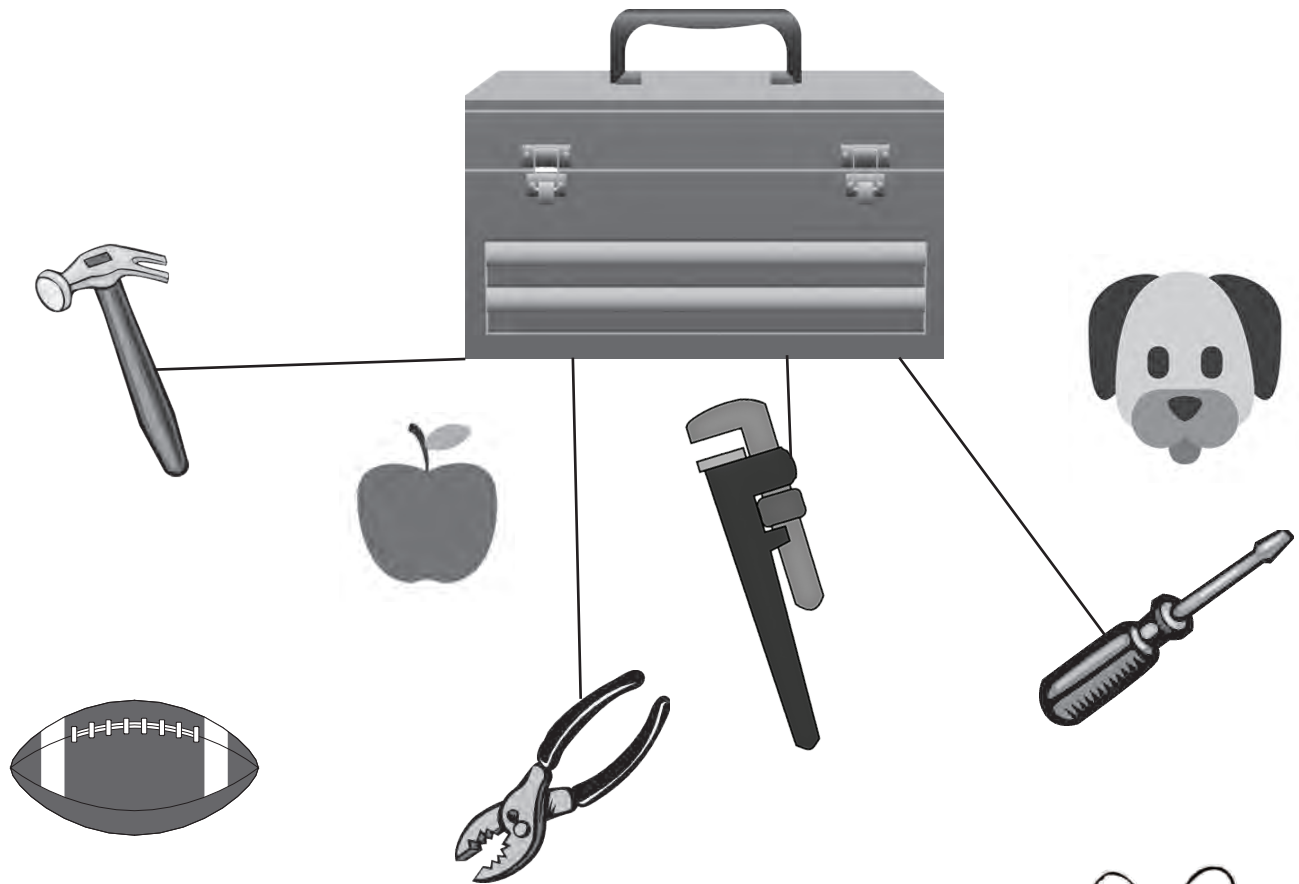

Take a  **peek**

at what you can become!



Career Peek



Retail Sales Supervisors oversee workers who sell a variety of products or services. The workers may sell things in a store. They may sell online or over the phone. They may visit customers in person. They sell things ranging from groceries and clothes to trips and big machines used in a factory. The supervisors help workers sell as much as possible. They make sure the workers treat customers well.

Retail Sales Supervisors oversee the selling of many different things. Fill in the blanks next to the picture to spell out some of the things you can buy.

ca m p e r



f o o d



c l o t h e s

p e t s



Take a  **peek**

at what you can become!



Career Peek

Salespersons work in stores. They sell items like clothes, furniture, cars or things for your home. They help customers find what they want. They answer questions about things for sale. They ring up sales.



Pretend you are a salesperson in a candy store. Help the customers **add** the coins.



$$\underline{10} \text{¢} + \underline{2} \text{¢} = \underline{12} \text{¢}$$



$$\underline{10} \text{¢} + \underline{4} \text{¢} = \underline{14} \text{¢}$$

$$\underline{25} \text{¢} + \underline{10} \text{¢} + \underline{2} \text{¢} = \underline{37} \text{¢}$$

Take a  peek

at what you can become!



South Dakota Career Peek

Marketing Cluster



Sales Representatives - Wholesale and Manufacturing, Except Technical and Scientific Products

sell goods for manufacturers to businesses, government agencies, and other groups. They contact customers and explain the products. These workers must know many details about the products they sell. They negotiate prices and answer questions.

Samuel the Sales Representative sold 135 boxes of candy to the local grocery store. If 75 of the boxes contain chocolates, how many of the boxes contain types of candy other than chocolates?

60 boxes

Stella the Sales Representative sold enough lumber to building supplies stores for the construction of 276 buildings. Of those buildings, 185 were homes. How many of the buildings were other types of structures?

91 structures

Sasha the Sales Representative sold 152 dresses to clothing stores last year. This year, she sold only 98 dresses. How many more dresses did she sell last year?

54 dresses



at what you can become!





Sales Representatives - Wholesale and Manufacturing, Technical and Scientific Products

sell high-tech goods and services to businesses, government agencies and other groups. The things they sell range from internet hosting services to computers and mechanical equipment. They contact customers and explain the products. These workers must know many details about the products they sell. They negotiate prices and answer questions.

Roberto is a Sales Representative who sells computers for the wholesale company he works for. His boss wants him to sell more computers to businesses or agencies in certain locations in their town. Use the map on the next page to answer the questions below.

If Roberto is to sell computers to businesses north of Main Street, what businesses or agencies should he sell to?

school and police station

If Roberto is to sell computers west of Willow Avenue, what businesses or agencies should he sell to?

police station and library



at what you can become!



Career Peek

Map for Sales Representatives - Wholesale and Manufacturing, Technical and Scientific Products

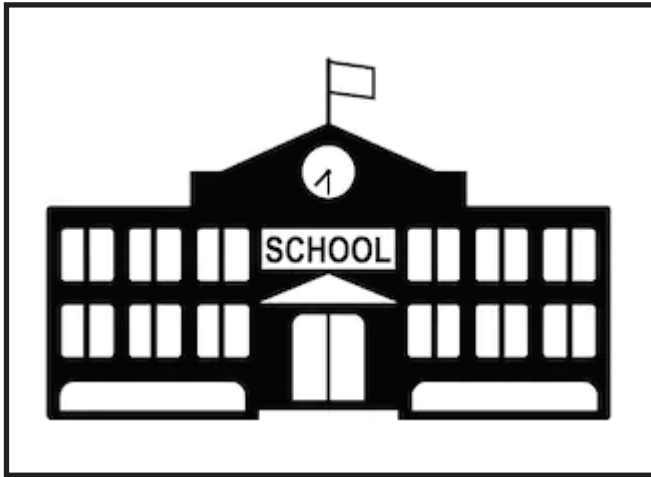

Main Street

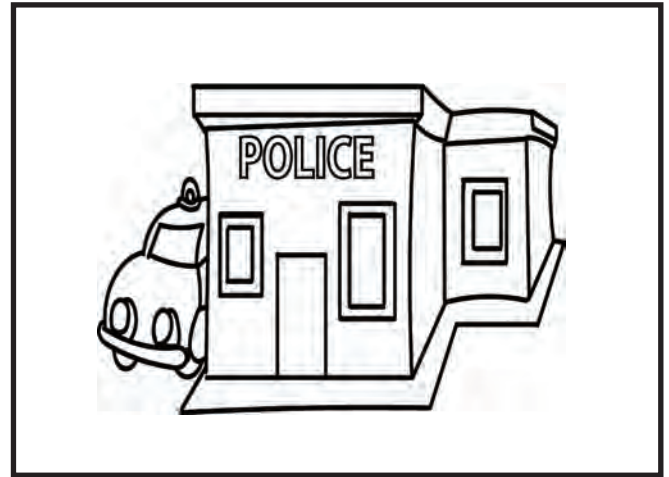

Main Street

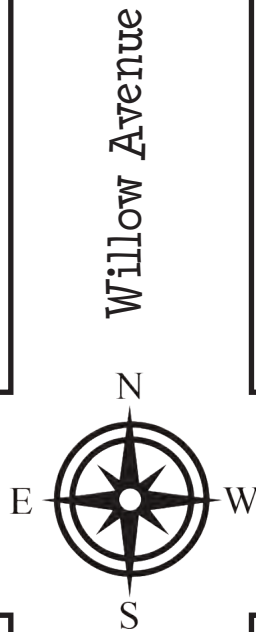

Willow Avenue

Willow Avenue

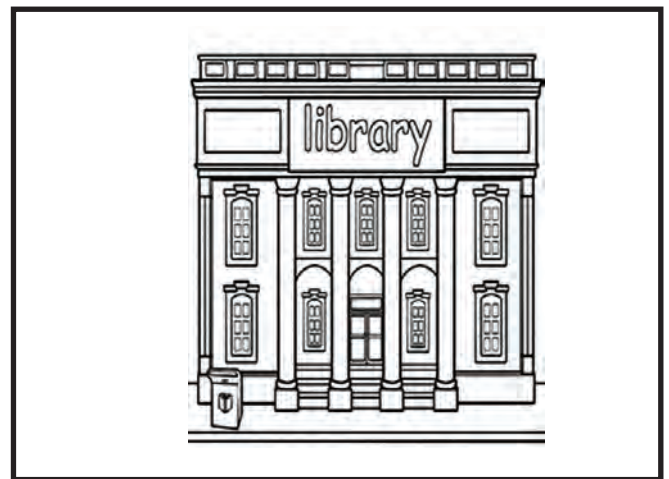
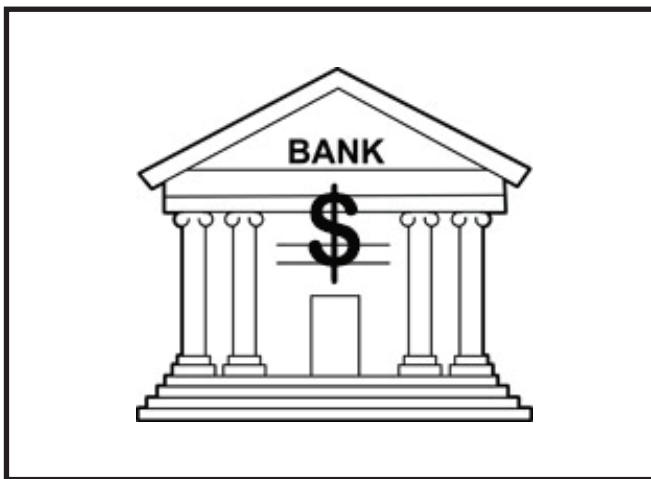

Take a  peek

at what you can become!



Career Peek

Social Workers try to help people make their lives better. Some work with schools, children or families. Others work with hospitals and patients. They talk to people about their lives and problems. They find places that can help people.



Write or draw something you need help with.

Who helps you?



Take a

peek

at what you can become!



Career Peek

Software Developers create software to run on computers and other devices. They will test the software. They help fix and update software. They write in languages called codes. The codes must be exactly right. Computers read these codes.



Draw the **shapes** that would come next in the pattern.

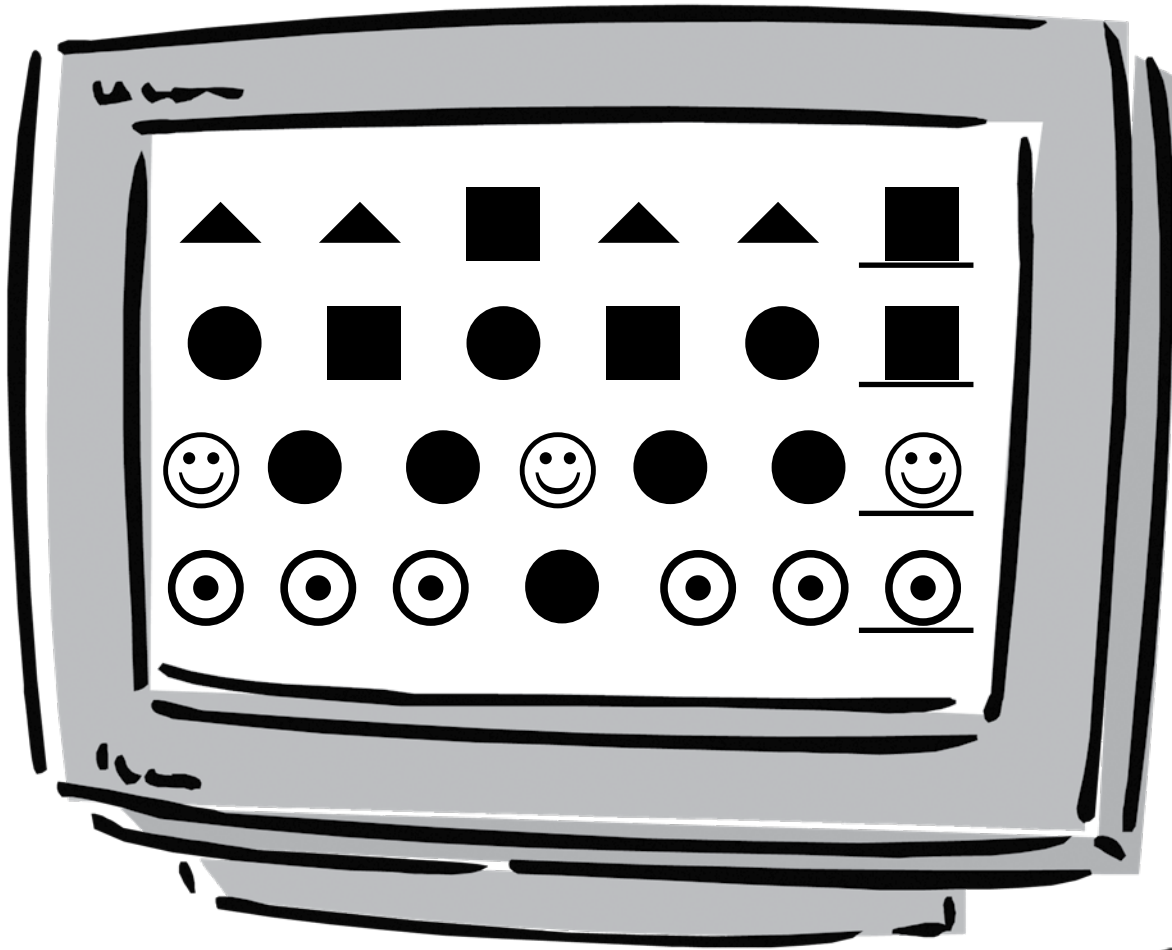

South Dakota Career Peeks

Agriculture, Food &
Natural Resources;
Science, Technology,
Engineering and
Mathematics

Soil and Plant Scientists look at soil, plants and crops.

They test dirt, plants and crops. Some figure out how to treat sick plants and trees. They help people figure out the best ways to use their land. They know what plants grow best in different kinds of soil.

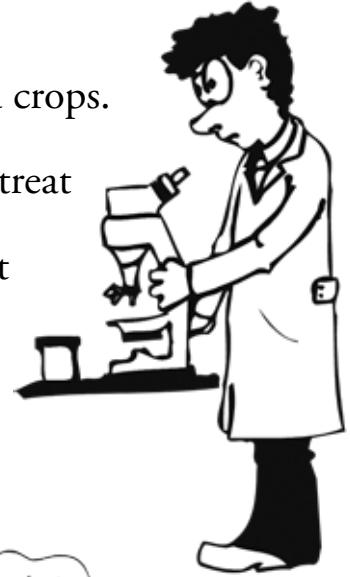

Match the crop, plant or tree to its picture.

This crop gets very tall before you pick it.



lily pad

Frogs like to hang out on these at the pond.



oak tree

A lot of people get this flower on Valentine's Day.



corn

This plant grows in hot, dry and sandy places.

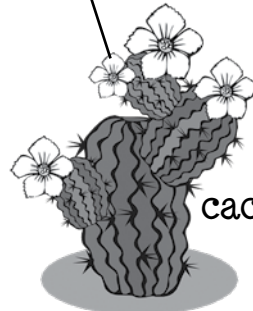

cactus

Squirrels like the nuts on this tree.



rose

Take a  peek

at what you can become!



Career Peeks

Teachers help students learn. They teach students reading, writing, spelling, math and much more.

They make up lessons and tests. They grade homework and tests. They meet with parents.

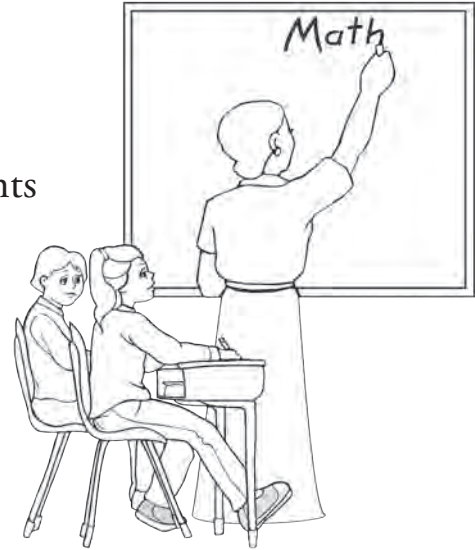

Look at the backpacks. Can you spot the differences? Circle them in the backpack on the right.



Take a  **peek**

at what you can become!



South Dakota Career Peeks

Transportation,
Distribution & Logistics

Truck Drivers move things from place to place. They haul many different things, like milk, candy, animals or logs. Some drive short routes. They stay at home each night. Some truck drivers drive a long way. They spend some nights away from home. Circle the correct answers.

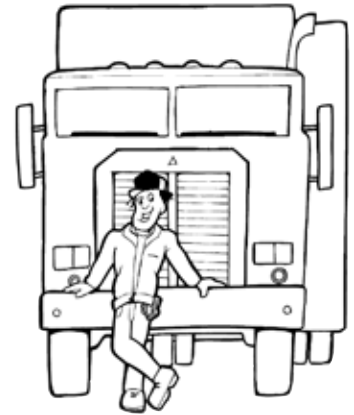

Which one holds more milk?



Which one weighs more?



Which one holds more ice cream?



Which one weighs more?

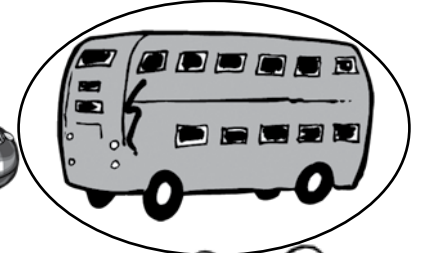

Take a  peek

at what you can become!



South Dakota Career Peeks

Agriculture, Food &
Natural Resources;
Health Science

Veterinarians are animal doctors. They take care of sick and injured animals. They give medicine to animals. They take care of pets. Some take care of farm animals. Some work at zoos. Vets teach owners how to keep their pets healthy.



Name the animals. Write your answers in the spaces.

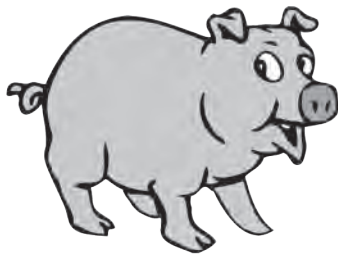

--- pig ---

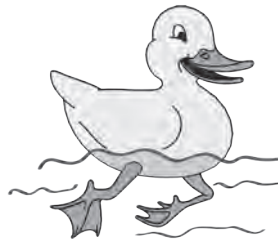

--- duck ---



--- dog ---

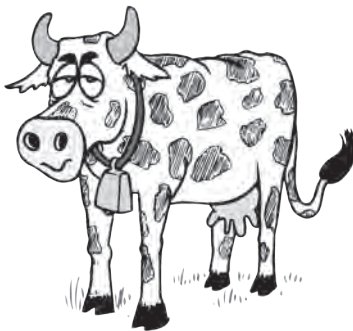

--- cow ---



--- cat ---



--- horse ---

Take a  **peek**

at what you can become!



Career Peek

Welders use heat to join metal pieces together. They also fill holes in metal products. Welding is strong and holds pieces together. It can be used for cars, trailers or bridges. It also connects steel beams or pipes.



Pretend you are a welder. You have to make the frame for a swing set like the one below. You will use seven separate pieces of iron pipe. On the picture below, circle the spots where you would need to weld the seven pieces together.

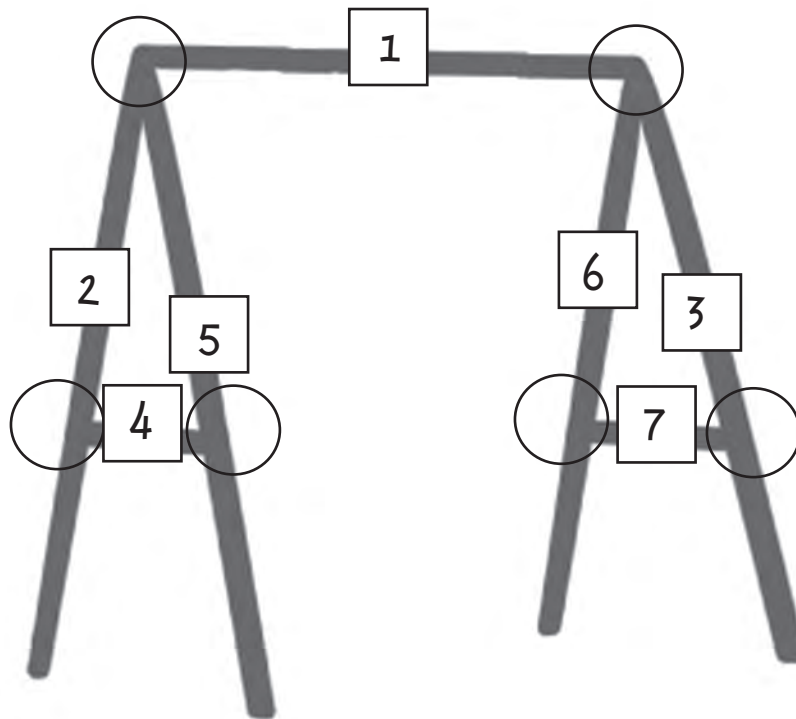

Take a  **peek**

at what you can become!

